



# One need. One system.

## Design

Our glazing systems are flexible and adaptable, designed to maximise profiles and parts. Most of them share same components to help you keep low stock levels.

Our casement systems have great versatility. They can be fabricated as internally or externally beaded and are compatible with both opening and fixed lights giving you the flexibility to create the most cost-effective solutions.

## Colour

We take care of the details, adapting our products to any requirements in terms of appearance. We offer an unlimited range of colours and finishes including painted and anodised with the best quality guaranteed by qualicoat seal.

Our glazing systems also allow dual colour to maximise bespoke options with different finishes inside and outside.

## Aesthetic

Our aluminium windows add elegance to every installation thanks to its slim profiles. Our systems maximises the amount of available daylight and our versatile range give you the freedom to achieve any required aesthetic style. Our flush, chambered, sculptured, flat faced or stepped sash sections, among others, give real versatility to create what you need, making our systems match any architectural style.

## Openings

From our classical casement windows, to our versatile tilt and turn system or our bi folding and sliding doors, we can provide a complete range of opening options.

# Casement windows



Innovation and aesthetics united in a single system. Kc51 casement window mixes a modern and contemporary appearance with optimal technical features, especially its safety and energy saving benefits.

Maximum size	1500x1500 mm top hung 900x1500 mm side hung
Maximum weight	50 kg
Maximum glazing	32,8 mm
Polyamide	24 mm
U <sub>w</sub> value	1,5 W/m <sup>2</sup> K

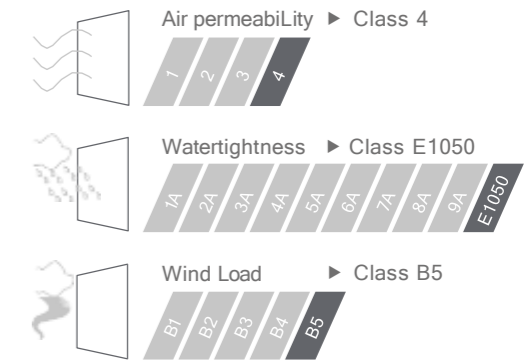

Air/Water/Wind tests according to standard BS6375-1

✓ PAS 24 Security    ✓ BS6375-2    ✓ BS6375-3

## Features

- Pas 24 tested
- Top and side hung applications
- 24 mm polyamides
- 4 to 33 mm glass options available
- Joined using mechanical corner cleats
- 75 mm polyamide sub frame section, for easy to install modular windows
- Egress options as standard
- Cills, add ons, curtain walling insert and coupler sections available
- Reverse adaptors for interior/exterior glazing

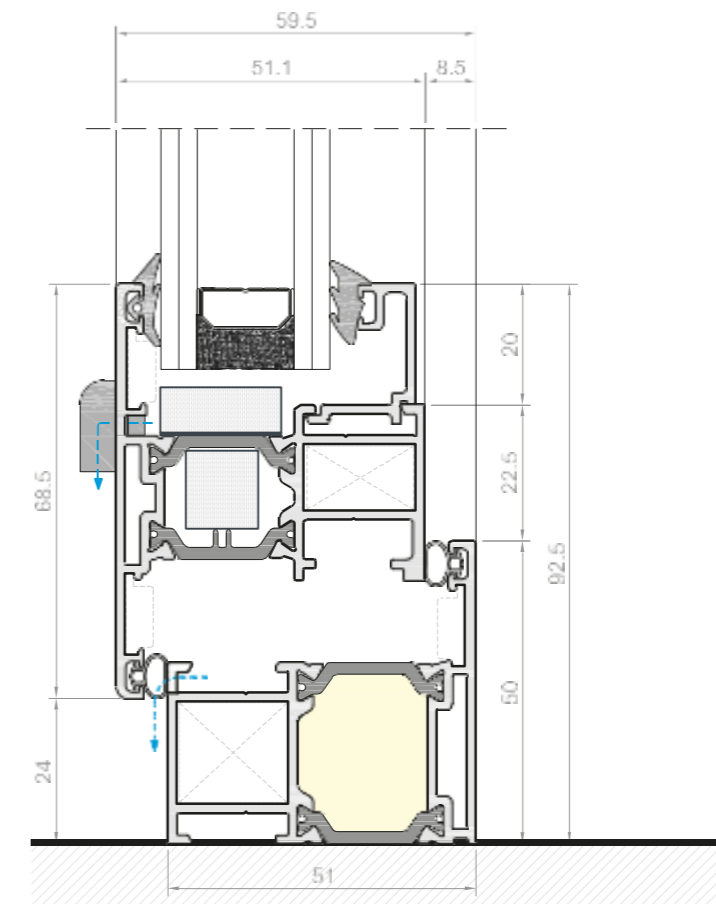

## TYPICAL CONFIGURATIONS

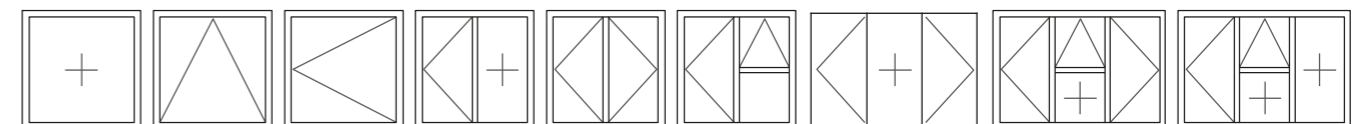

# Casement window.

Aluminium windows make a stunning statement in any home. Casement aluminium windows have slim frames that maximise the amount of natural light, making them perfect for both traditional and modern homes.

With a choice of design options, this system comes with a multitude of practical features for today's modern day living, while exceeding the energy performance requirements of current part I building regulations.



Maximum size	1500x1500 mm top hung 900x1500 mm side hung
Maximum weight	50 kg
Maximum glazing	56 mm
Polyamide	32 mm
U <sub>w</sub> value	1,2 W/m²K



Air/Water/Wind tests according to standard BS6375-1

✓ PAS 24 Security    ✓ BS6375-2

## Features

- PAS 24 tested
- Top and side hung applications
- Joined using mechanical corner cleats
- 75 mm polyamide sub frame section, for easy to install modular windows
- Egress option available
- Slimline internal glazing option
- Cills, add ons, curtain walling insert & coupler sections available
- flush sash option available

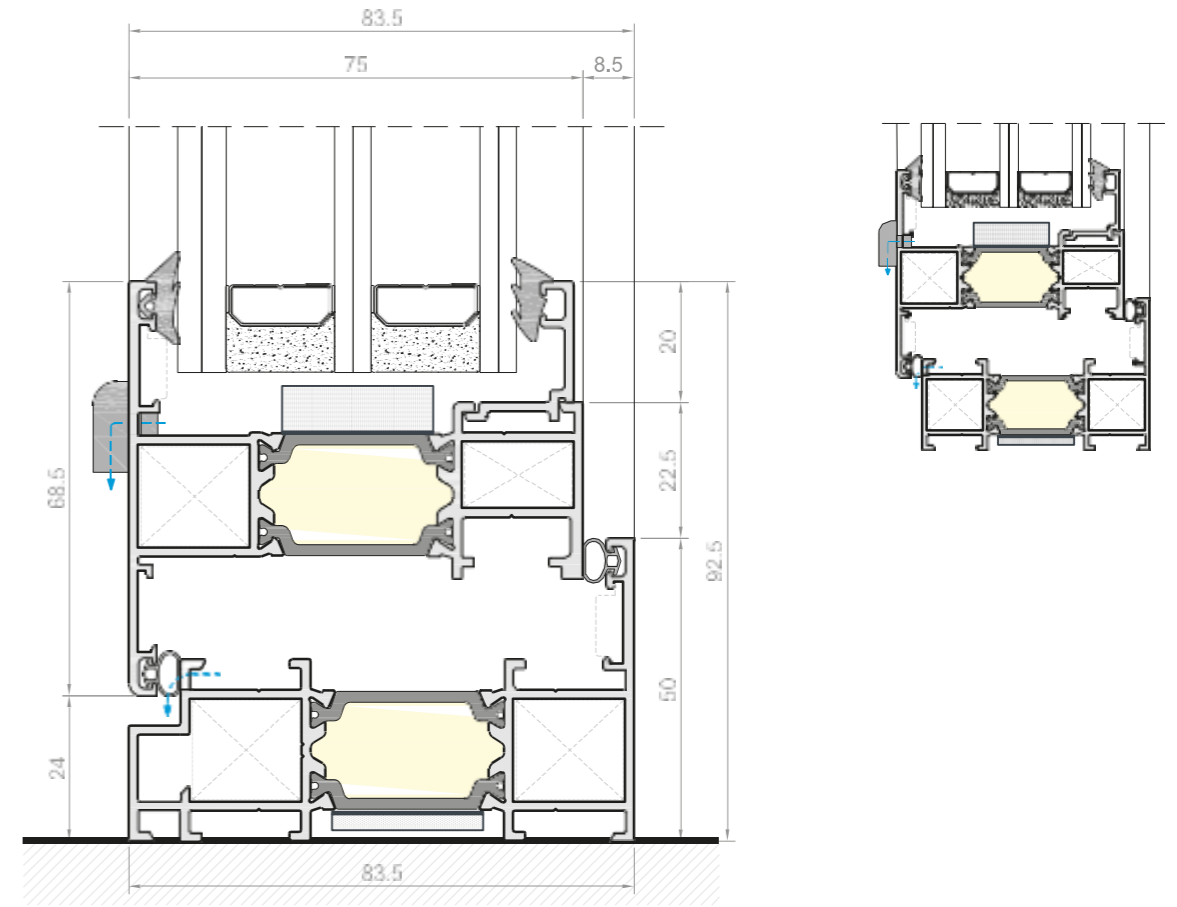

TYPICAL CONFIGURATIONS

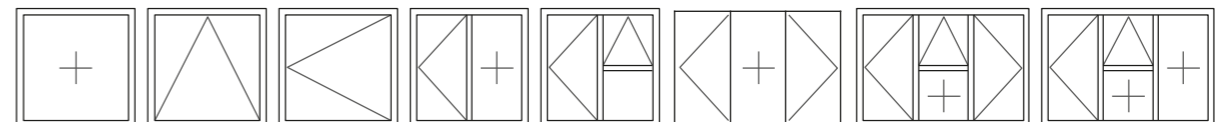

# Casement window.



A modern design that maximizes the glazed area is a must in any window system. Ks59 steel lookalike casement window is designed to mimic steel windows. This open out window system unites performance and practicality to give a contemporary look where slim sightlines and profiled sections stand out, making it an ideal choice for both refurbishments and new builds.

Maximum size	1200x1500 mm top hung 600x1200 mm side hung
Maximum weight	50 kg
Maximum glazing	28 mm
Polyamide	24/32 mm
U <sub>w</sub> value	1,4 W/m²K

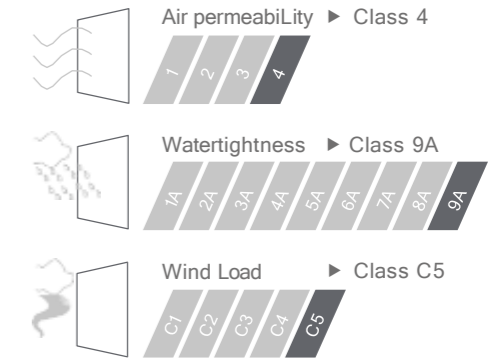

Air/Water/Wind tests according to standard BS6375-1



## Features

- Top and side hung applications
- 32 mm polyamide
- 28 mm glass, as standard
- Joined using mechanical corner cleats
- Egress options available
- Cills, add ons and coupler sections available

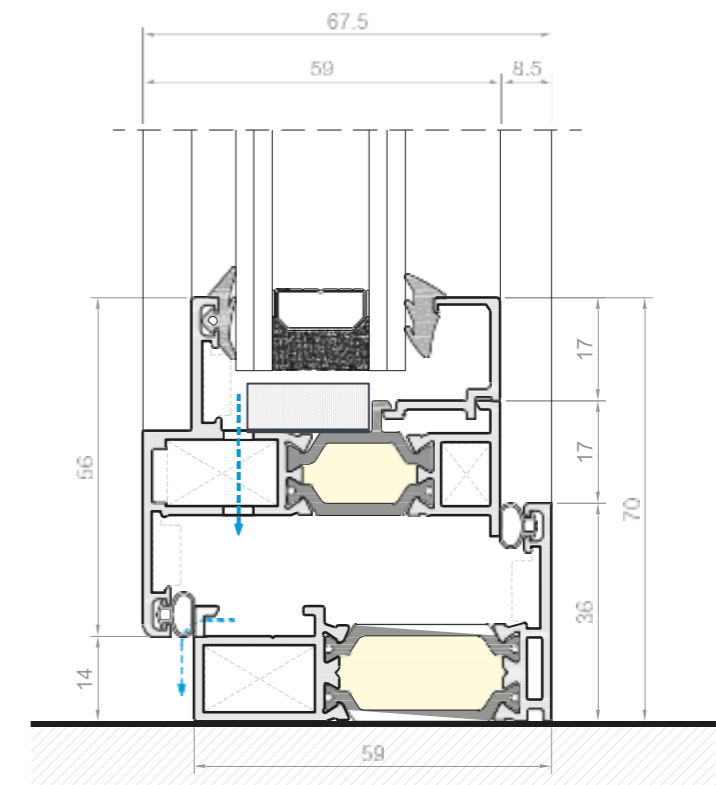

## TYPICAL CONFIGURATIONS

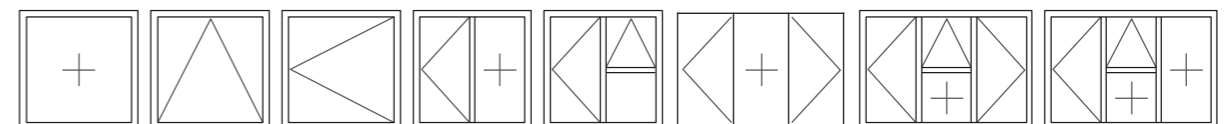

# Tilt & Turn window



A system capable of adapting to the aesthetic and functional needs of any building is essential in architecture. Kt51 tilt & turn offers a huge range of adaptable options for any room, thanks to the combination of its opening possibilities. Furthermore, its technical features are excellent, making this system one of the most complete in our range.

## Features

- Top and side hung applications, as well as tilt & turn
- 32 mm polyamide
- 28 mm glass, as standard
- Joined using mechanical corner cleats
- Egress options available
- Cills, add ons, curtain walling insert and coupler sections available



Maximum leaf size	1500x2100 mm
Maximum weight	90 kg
Maximum glazing	32,8 mm
Polyamide	24/32 mm
U <sub>w</sub> value	1,4 W/m²K

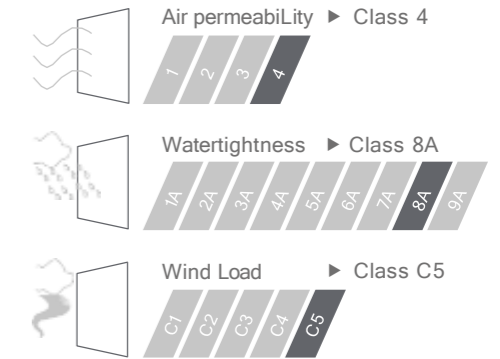

Air/Water/Wind tests according to standard BS6375-1

PAS 24 Security 
  BS7950 Security 
  BS6375-2

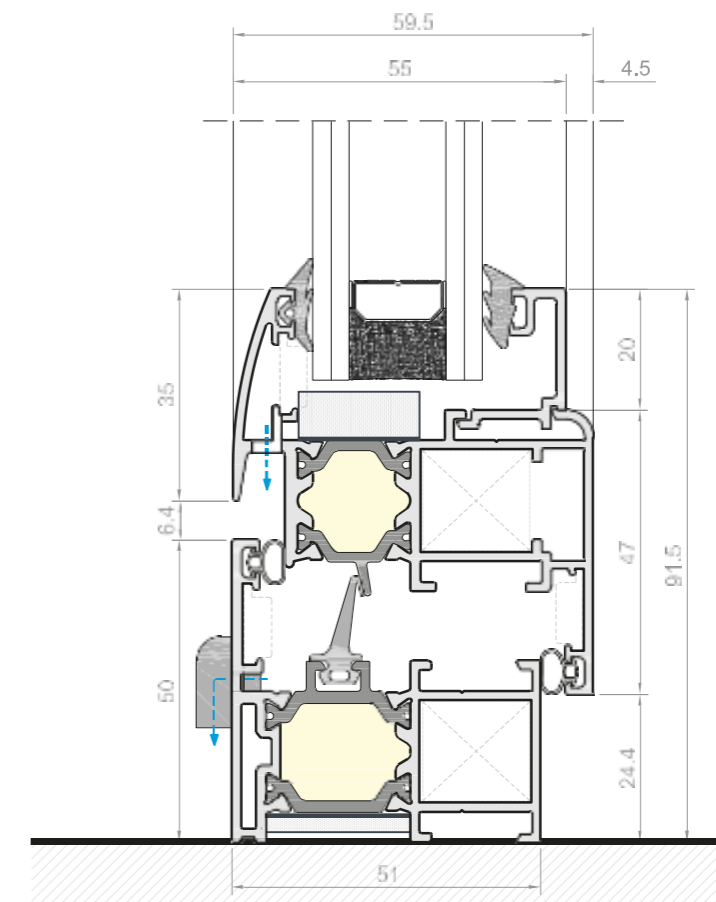

## TYPICAL CONFIGURATIONS

